



ARDENTE DUO

120x43.DGS

FIREPLACE INSERT / AIR



ENERGY CLASS



BASIC INFORMATION ABOUT THE PRODUCT



- Tunnel type insert for double-sided or island construction.
- Insert with an enlarged, deep rectangular combustion chamber enabling large loads.
- Tilttable cast iron grate for easy cleaning of the fireplace.
- A new type of guillotine with service access.
- Two heat-resistant decorative DECOR glasses as standard (operating temperature up to 800°)
- Possibility to order dedicated covers (powder-coated steel in the color of the insert).
- Clean glass system: double-sided air deflectors with air curtains.
- Steel doors made of a special profile ensuring stiffness and resistance to high temperatures.
- The insert elements are produced using modern CNC devices (2D, 3D laser, press brakes).
- The insert jacket is made of P265GH boiler steel according to EN 10028-2.

Nominal power [kW]	22
Heating load range [kW]	11-28,5
Thermal efficiency [%]	76,5
CO emissions (at 13% O2) [g/m3]	0,036
Pollen emission [g/m3]	0,431
Average fuel consumption [kg/h]	6,8
Recommended dimensions of outlet grilles [cm2]	1540-1760
Recommended dimensions of inlet grilles [cm2]	880-1430
Glass dimensions [mm]	1203x430
Flue diameter [mm]	198
Inlet diameter [mm]	123
Weight [kg]	421
Efficiency factor	101,9



ARDENTE DUO

120x43.DGS

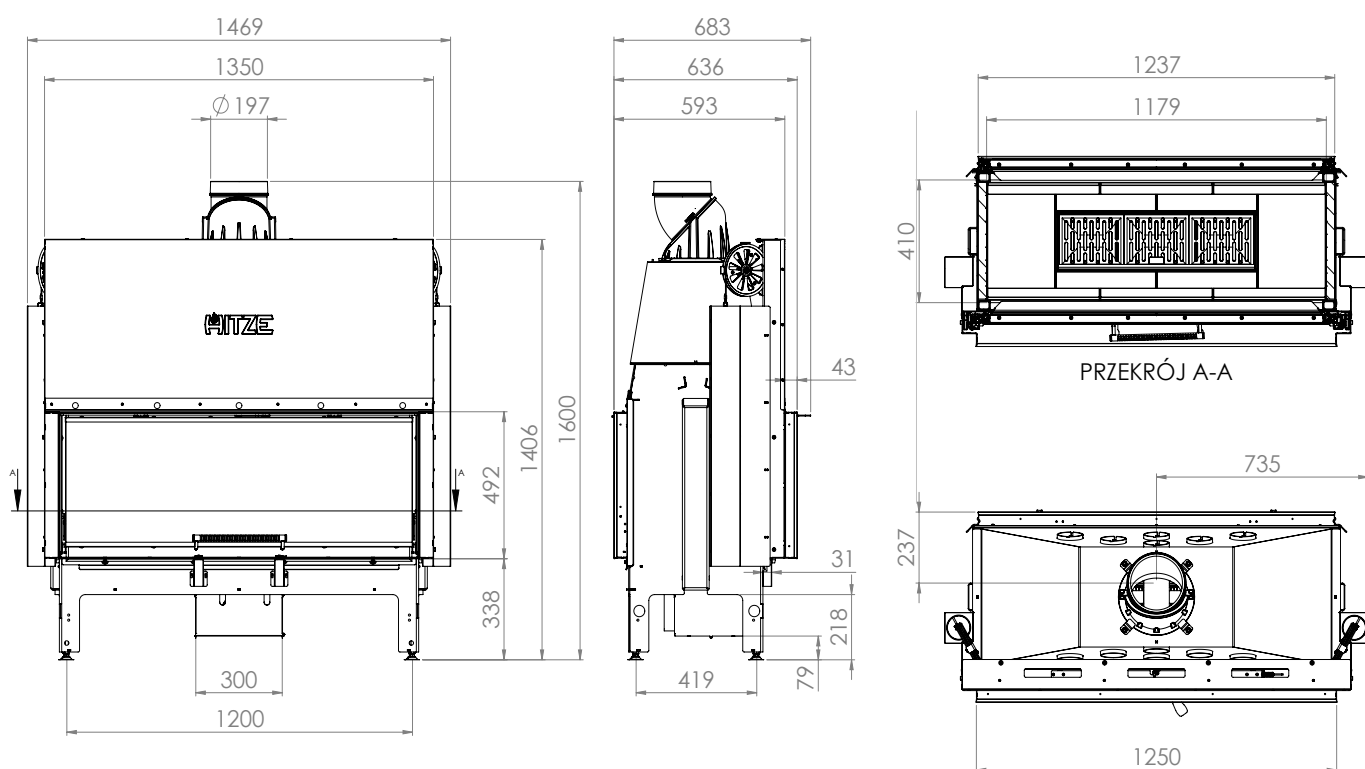

ARDENTE DUO

120x43.DGS